

MOTOR SELECTION GUIDE

Please complete questions 1 to 7

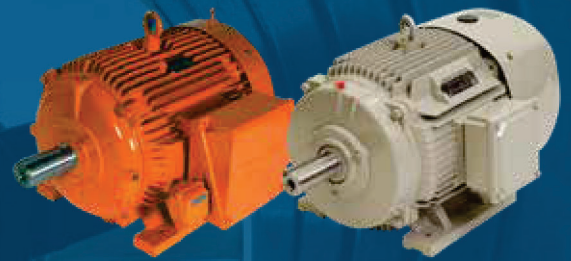

marathon™ Gearboxes **marathon®** Motors

1. WHAT MOTOR POWER IS REQUIRED?

NOTE: 1 HORSE POWER (HP) = 0.75kW ie 10 HP x 0.75 = 7.5 kW

- | | | |
|----------------------------------|----------------------------------|--------------------------------|
| 0.37 kW <input type="checkbox"/> | 4.0 kW <input type="checkbox"/> | 30 kW <input type="checkbox"/> |
| 0.55 kW <input type="checkbox"/> | 5.5 kW <input type="checkbox"/> | 37 kW <input type="checkbox"/> |
| 0.75 kW <input type="checkbox"/> | 7.5 kW <input type="checkbox"/> | 45 kW <input type="checkbox"/> |
| 1.1 kW <input type="checkbox"/> | 11 kW <input type="checkbox"/> | 55 kW <input type="checkbox"/> |
| 1.5 kW <input type="checkbox"/> | 15 kW <input type="checkbox"/> | 75 kW <input type="checkbox"/> |
| 2.2 kW <input type="checkbox"/> | 18.5 kW <input type="checkbox"/> | 90 kW <input type="checkbox"/> |
| 3.0 kW <input type="checkbox"/> | 22 kW <input type="checkbox"/> | |

Other (please specify)

2. WHAT SPEED (RPM) IS THE MOTOR REQUIRED TO DO?

- | | |
|--|--|
| 3000 RPM (2 pole) <input type="checkbox"/> | 1000 RPM (6 pole) <input type="checkbox"/> |
| 1500 RPM (4 pole) <input type="checkbox"/> | 750 RPM (8 pole) <input type="checkbox"/> |

Other (please specify)

3. WHAT MOTOR VOLTAGE IS REQUIRED?

- | |
|--|
| 240V domestic power (Single Phase) <input type="checkbox"/> |
| 415V industrial power (Three Phase) <input type="checkbox"/> |

Other (please specify)

4. HOW IS THE MOTOR MOUNTED?

- | |
|--|
| Foot mount (B3) <input type="checkbox"/> |
| Foot & flange mount (B35) <input type="checkbox"/> |
| Flange mount (B5) <input type="checkbox"/> (B14) |

Other (please specify)

5. WHAT IS THE MOUNTING ORIENTATION?

- | |
|--|
| Horizontal <input type="checkbox"/> |
| Vertical shaft up <input type="checkbox"/> |
| Vertical shaft down <input type="checkbox"/> |

Other (please specify)

6. WHAT IS THE MOTOR CONSTRUCTION OF?

- | |
|---------------------------------------|
| Rolled steel <input type="checkbox"/> |
| Cast alloy <input type="checkbox"/> |
| Cast iron <input type="checkbox"/> |

Other (please specify)

8. WHAT ENVIRONMENT IS THE MOTOR USED IN?

- | | |
|---|----------------------------------|
| Wet area <input type="checkbox"/> | Indoor <input type="checkbox"/> |
| Dust area <input type="checkbox"/> | Outdoor <input type="checkbox"/> |
| Hazardous location <input type="checkbox"/> | |
| Other (please specify) <input type="checkbox"/> | |
-

9. WHAT IS THE MOTOR SHAFT DIAMETER?

- | | | |
|--------------------------------|--------------------------------|--------------------------------|
| 14 mm <input type="checkbox"/> | 38 mm <input type="checkbox"/> | 60 mm <input type="checkbox"/> |
| 19 mm <input type="checkbox"/> | 42 mm <input type="checkbox"/> | 65 mm <input type="checkbox"/> |
| 24 mm <input type="checkbox"/> | 48 mm <input type="checkbox"/> | 75 mm <input type="checkbox"/> |
| 28 mm <input type="checkbox"/> | 55 mm <input type="checkbox"/> | 80 mm <input type="checkbox"/> |

Other (please specify)

10. IF THE MOTOR IS FOOT MOUNT, PLEASE FILL IN THE DIMENSIONS OF THE FOOT.

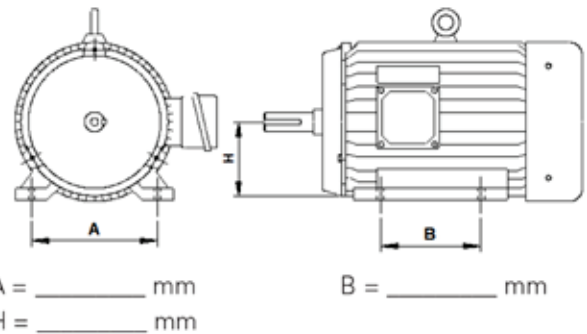

11. IF THE MOTOR IS FLANGE MOUNT, PLEASE FILL IN THE DIMENSIONS OF THE FLANGE.

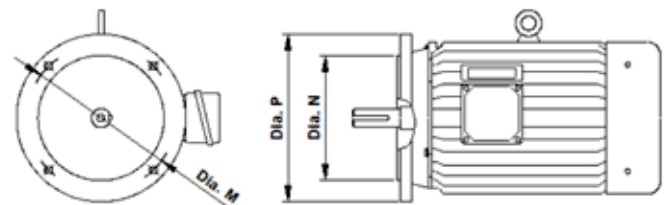

12. LIST ANY SPECIAL OR ADDITIONAL REQUIREMENTS?
